



Co-funded by the  
Erasmus+ Programme  
of the European Union



# Wood protection

Kristýna Šimůnková

Kateřina Hájková



Co-funded by the  
Erasmus+ Programme  
of the European Union



## CULS lessons

- Destruction of wood by biotic pests and abiotic agents
- Physical and structural protection of wood
- Wood protection by chemical means
- Ways of applying chemical protection
- Wood drying
- Surveys and sterilization of wooden structures, rehabilitation
- Hydrothermal treatment of wood



## Destruction of wood by biotic pests and abiotic agents

- Durability of wood
- Wood degrading agents
  - Biotic agent
  - Abiotic agent





Co-funded by the  
Erasmus+ Programme  
of the European Union



## Physical and structural protection of wood

- Wet and dry protection
- Structural protection

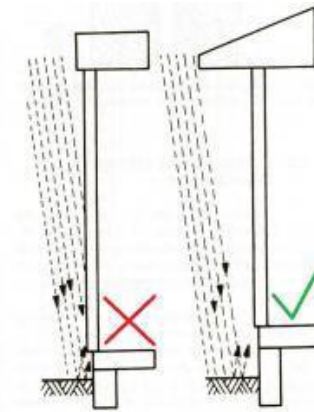
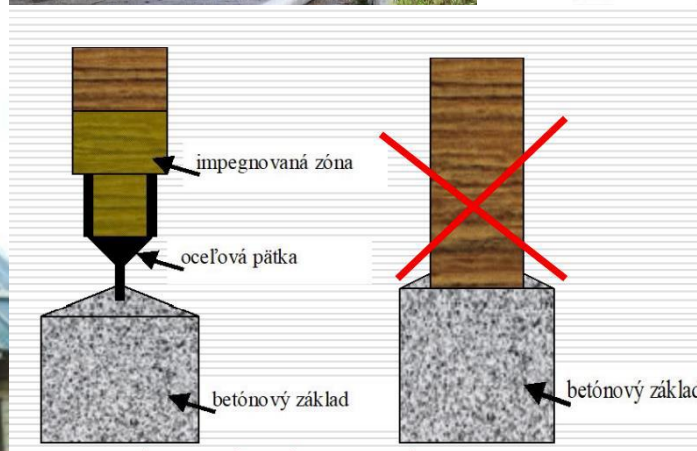
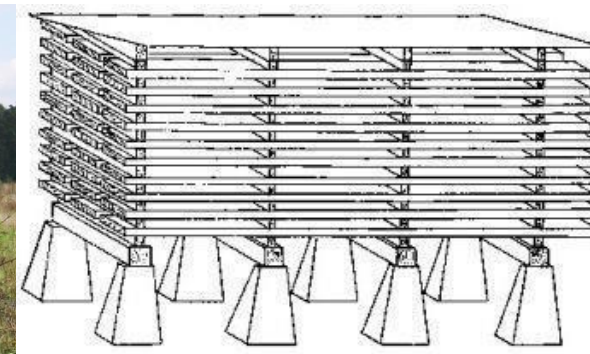



# Wood protection by chemical means and ways of applying chemical protection

- Fungicides, insecticides, biocides, flame retardants and weather corrosion inhibitors
- Non-pressure and pressure methods

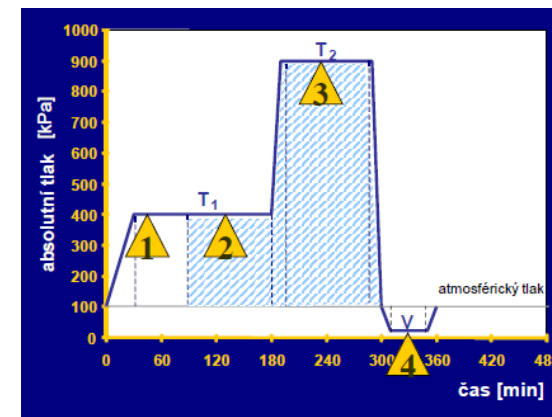
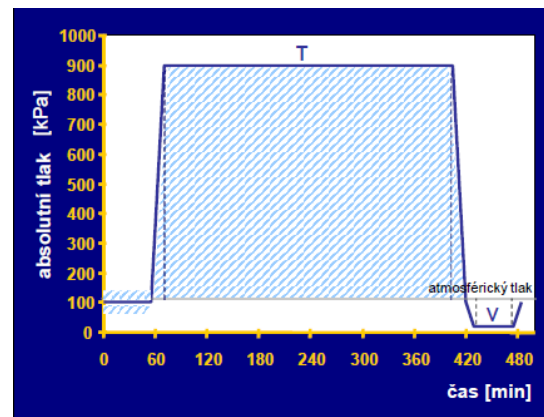
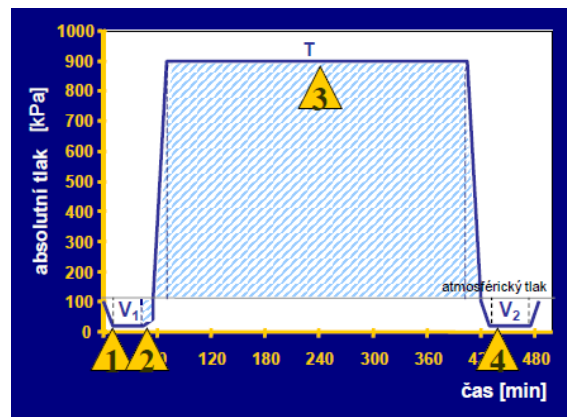



Co-funded by the  
Erasmus+ Programme  
of the European Union



## Wood drying

- Natural and artificial drying

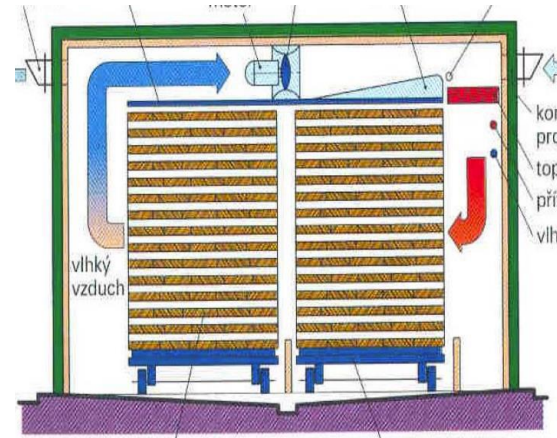



Co-funded by the  
Erasmus+ Programme  
of the European Union



# Diagnostics and sterilization of wooden structures, remediation

- Various diagnostic methods
- Types of sterilization
- Remediation options

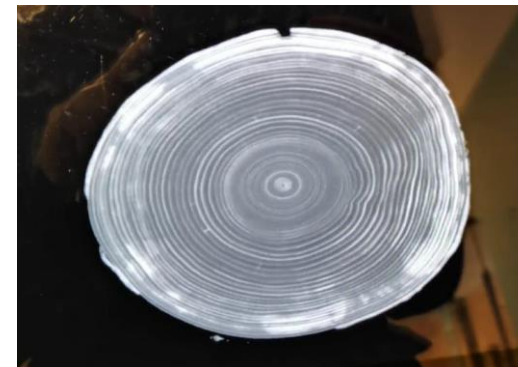
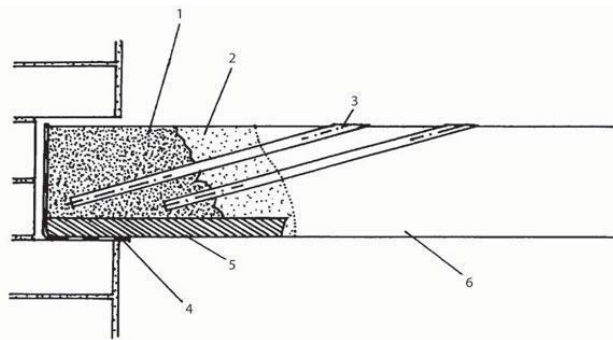
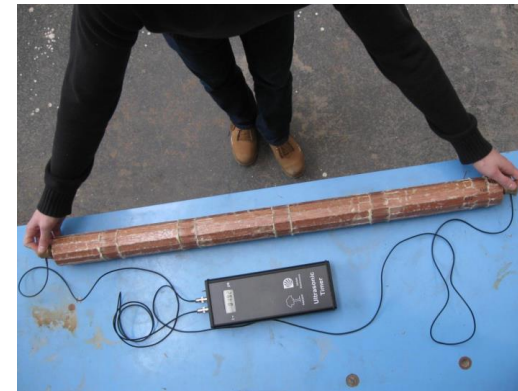



Co-funded by the  
Erasmus+ Programme  
of the European Union



# Modifications and hydrothermal treatment of wood

- Chemical, physical and biological
- Hydrothermal treatment







Co-funded by the  
Erasmus+ Programme  
of the European Union



## Background for teaching and research

- Artificial weathering in UV chambre and Xenotest
- Natural weathering
- Climat chamber

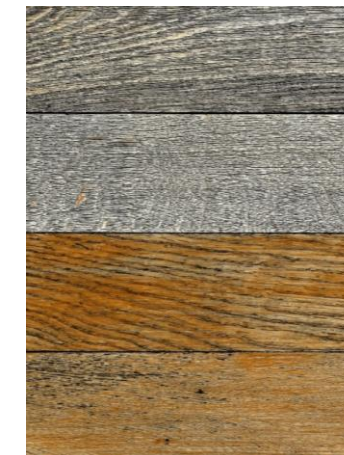
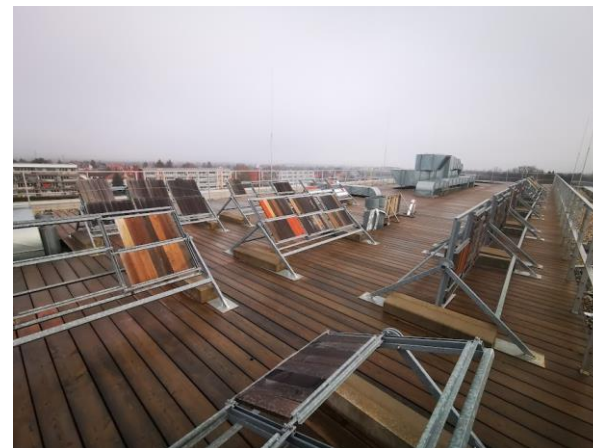
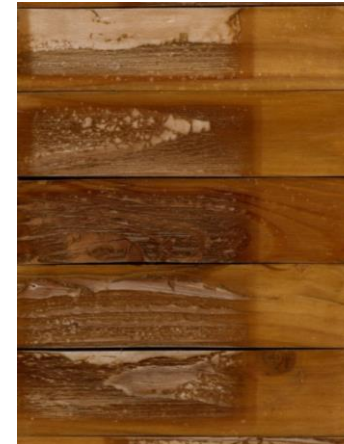



Co-funded by the  
Erasmus+ Programme  
of the European Union



## Background for teaching and research

- Colour and gloss measurement
- Contact angle and free surface energy
- Microscopy

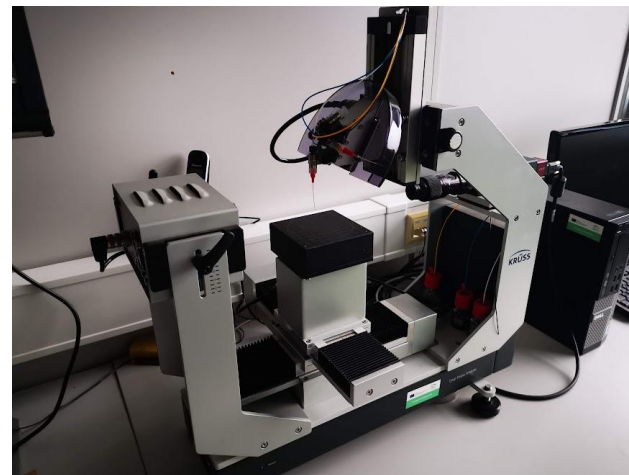



## Researches

- Ing. Kristýna Šimůnková, Ph.D. – Final thesis
- Durability of modified wood to selected species of wood-destroying fungi and insects
  - Finding suitable wood modifications on a natural basis in terms of long-term stability and resistance to weathering and attack by wood-destroying insects, fungi and molds
  - Caffeine, lavender essential oil

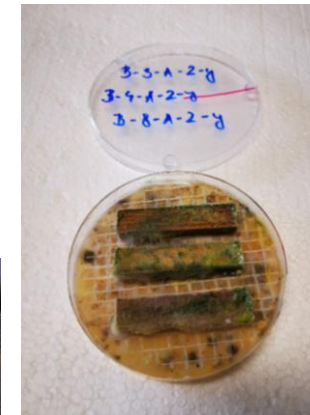



## Researches

- Ing. Ondřej Dvořák – Final thesis
- Effect of surface treatment of wood on the overall life of transparent exterior coating systems
  - The effect of the underlying wood species and its modification on the overall life of the coating system
  - The effect of modification of the coating system with UV stabilizers and the effect of the polymer base on the overall resistance of the coating
  - Influence of the upper hydrophobic layer

Testing time	Spruce - REF	Spruce + Coating
0 months		
6 months		
12 months		
	Oak - REF	Oak + Coating
0 months		
6 months		
12 months		



## References

- Deml, M. 2006. *Serpula lacrymans*: <https://www.biolib.cz/en/taxon/id60230/> (online 09-02-2023)
- Gašparík, M.; Macků, J. 2015. *Wood drying* (in Czech): <https://www.agrojournal.cz/clanky/suseni-dreva-91> (online 09-02-2023)
- Hydro-X. 2017. *Realization* (in Czech): <http://hydro-x.cz/realizace/> (online 09-02-2023)
- IZOLACE.CZ. 2020. *Facades with wood* (in Czech): <https://www.izolace.cz/clanky/fasady-se-drevem/> (online 09-02-2023)
- Kobeticova, K. et al. 2020. Antifungal Activity of Methylxanthines Based on Their Properties. *BioResources*, 2020, 15, 4, 8110–8120.
- Oberhofnerová, E. et al. 2019. Comparison of Exterior Coatings Applied to Oak Wood as a Function of Natural and Artificial Weathering Exposure. *Coatings*, 9, 12, 1–15.
- Pánek, M. et al. 2021. Efficacy of Caffeine Treatment for Wood Protection-Influence of Wood and Fungi Species. *Polymers*, 13, 21, 1–14.
- Pánek, M. et al. 2019. Effectiveness of Two Different Hydrophobic Topcoats for Increasing of Durability of Exterior Coating Systems on Oak Wood. *Coatings*, 9, 5, 1–13.
- Pánek, M. et al. 2019. Durability of the Exterior Transparent Coatings on Nano-Photostabilized English Oak Wood and Possibility of Its Prediction before Artificial Accelerated Weathering. *Nanomaterials*, 9, 11, 1–21.
- Reinprecht, L.; Pánek, M. 2016. *Durability and protection of wood* (in Czech), CZU, 132.
- Šimůnková, K. et al. 2022. Lavender oil as eco-friendly alternative to protect wood against termites without negative effect on wood properties. *Scientific Reports*, 2022, 12, 1, 1–11.
- Šimůnková, K. et al. 2021. Caffeine - Perspective natural biocide for wood protection against decaying fungi and termites. *Journal of Cleaner Production*, 304, 127110, 1–8.
- Šimůnková, K. et al. 2020. Effect of Artificial Weathering and Temperature Cycling on the Adhesion Strength of Waterborne Acrylate Coating Systems Used for Wooden Windows. *Journal of Green Building*, 15, 1, 3–14 ISSN: 1552-6100.
- Šimůnková, K. et al. 2019. Durability of Selected Transparent and Semi-Transparent Coatings on Siberian and European Larch during Artificial Weathering. *Coatings*, 9, 1, 1–16.
- Šimůnková, K. et al. 2018. Comparison of Selected Properties of Shellac Varnish for Restoration and Polyurethane Varnish for Reconstruction of Historical Artefacts. *Coatings*, 8, 4, 1–12.
- Štěrbová, I. et al. 2021. Influence of different exposition of larch wood facade models on their surface degradation processes. *Central European Forestry Journal*, 67, 1, 45–53.